

Bin lifter type HKV

Simply powerful

PRESTO HKVs can be used wherever recyclable and waste materials are collected decentrally in large waste and transfer containers. Lift and tip devices are available as integrated, mobile and stationary versions. Collection containers are tipped into open containers, hoppers or compactors using the HKV.

PRESTO bin lifters are your functional aid for the effective handling of recyclable materials. We design the optimum solution for your disposal needs.

Individually usable

for materials and recyclables like paper and cardboard, printing and punching waste, packaging and commercial waste, residual waste and foil.

for industries such as Industrial and waste disposal companies, logistics centers, paper processing, the printing and packaging industry, wholesalers and many more..



Versatile & efficient

- Almost all DIN collection bins and special containers can be tilted
- Spigot and / or comb pick-up (120 - 1100 l MGBs) selectable
- Easy steering and fast movement (mobile version)
- Two-hand operation with acoustic and / or visual signal

Economical & elegant

- Flexible installation location - plug and play (fixed base, power supply required; mobile version)
- Low-noise operation of < 60 dB (A)
- RAL color selection from a variety of lead and chromium free paints
- Many years of experience in construction, design and project planning

integrated skip lift containerr

integrated roll on, roll off container

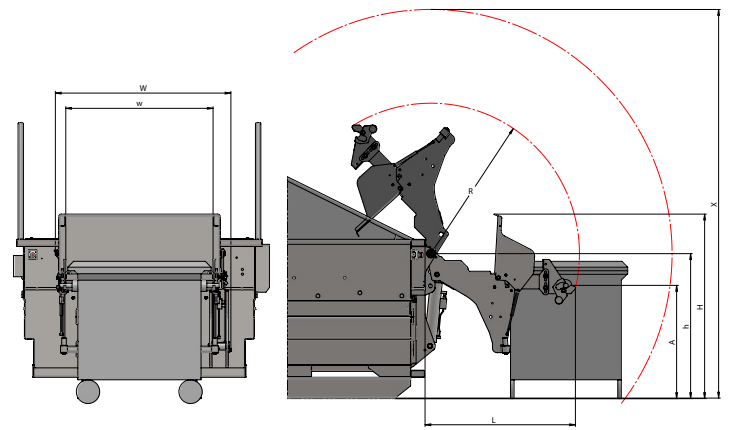
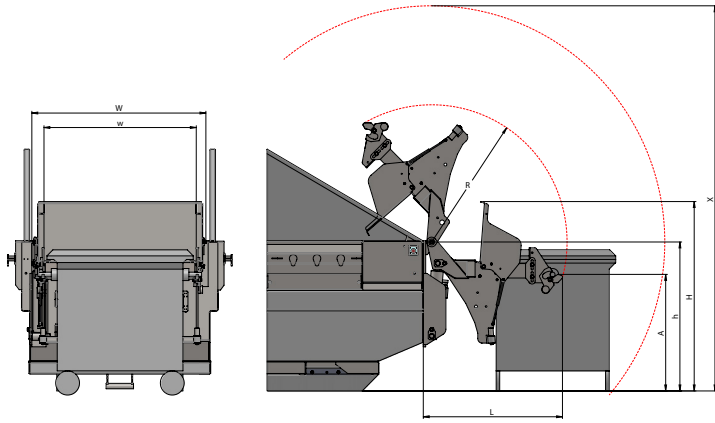

movable

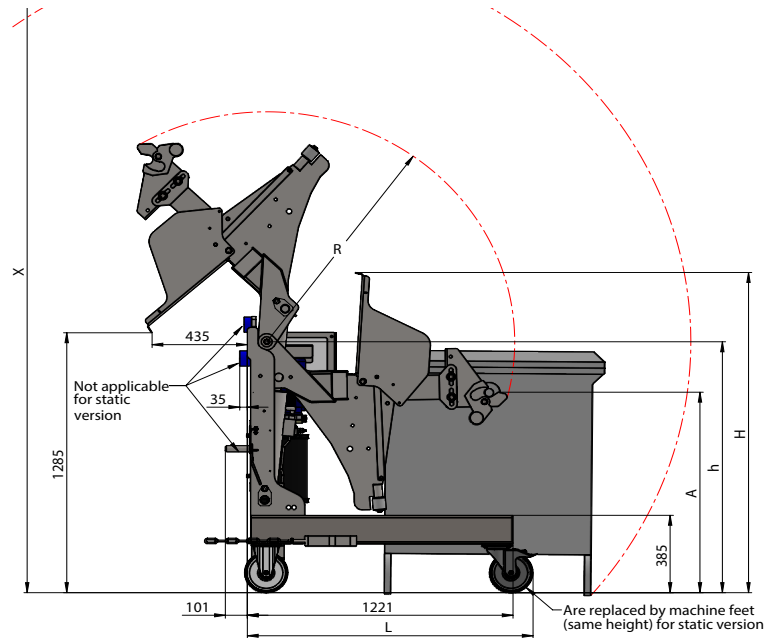
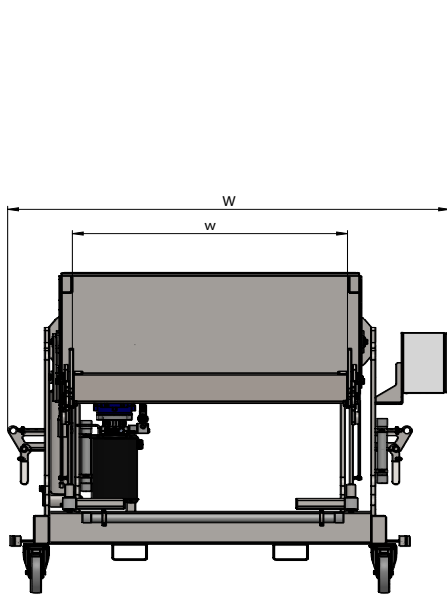

		movable	static	integrated skip lift containerr	integrated roll on, roll off container
Length (L)	mm	1315	1220	1170	1290
Width (W)	mm	2010	2010	1465	1505
Height retracted (H)	mm	1585	1585	1575	1565
Pivot point height (h)	mm	1245	1245	1240	1230
Pick-up height (A)	mm	995	995	970	960
Pick-up swivel radius (R)	mm	1140	1140	1140	1275
Required minimum height (X)	mm	2750 - 3300	2750 - 3300	2750 - 3300	2750 - 3300
Lifting force	kg	500 / 750	500 / 750	500 / 750	500 / 750
Cycle time	s	30	30	30	30
Machine weight	kg	480 - 650	480 - 650	350 - 510	350 - 510
Motor power rating	kW	3	3	-	-
Electrical power supply		3 L / N / PE; 400 V, 50 Hz		-	-

Subject to technical changes; the figures are rounded and may vary depending on the equipment version.

Other machine variants such as (hydraulic) comb pick-up, raised pivot point, for special containers with special pick-up on request.

PRESTO GmbH & Co. KG

Gewerbepark 4 | D-49196 Bad Laer
Fon +49 5424 2927-0 | Fax +49 5424 2927-90
kontakt@presto.eu | www.presto.eu

04/2026

more data-
scan hier

